

TRENCH CODE	CHANNEL PART NO	U	D
1000N	150150	0.150	0.150
1001	150155	0.150	0.155
1002	155160	0.155	0.160
1003	160165	0.160	0.165
1004	165170	0.165	0.170
1005	170175	0.170	0.175
1005N	175175	0.175	0.175
1006	175180	0.175	0.180
1007	180185	0.180	0.185
1008	185190	0.185	0.190
1009	190195	0.190	0.195
1010	195200	0.195	0.200
1010N	200200	0.200	0.200
1011	200205	0.200	0.205
1012	205210	0.205	0.210
1013	210215	0.210	0.215
1014	215220	0.215	0.220
1015	220225	0.220	0.225
1015N	225225	0.225	0.225

SPECIFICATION DETAIL: QUICK-TRENCH CHANNELS ARE 1 METER (39.4 IN) POLYPROPYLENE SECTIONS WITH UNIFORM EXTERIOR AND 0.5% SLOPED OR NEUTRAL INTERIOR FULL RADIUS BOTTOM FOR EFFICIENT LIQUID DRAINAGE. CHANNELS MATE TO ADJACENT SECTIONS VIA INTEGRAL EARS, CLIPS, AND 25 MM (1 IN) OVERLAPPING TONGUE. EACH CHANNEL CONTAINS 4 RECEPTACLES FOR FIXATION TO #REBAR VIA WIRE OR CABLE TIE. UP TO 15 METER (49.2 FT) SLOPED DRAINAGE RUN IS POSSIBLE TO A SINGLE END POINT. UP TO 30 METER (98.4 FT) SLOPED DRAINAGE RUN IS POSSIBLE TO A CENTER POINT COLLECTION POINT. NEUTRAL CHANNELS ARE AVAILABLE TO EXTEND RUN LENGTHS OR WHERE LEVEL TRENCH DRAIN IS DESIRED. CHANNELS HAVE STAGGERED SEMI-CIRCULAR CUTOUTS ON EACH SIDE AT BOTTOM TO ENABLE CONCRETE FLOW UNDER LEGS. DRAINAGE OPTIONS INCLUDE BOTTOM OUTLET, END OUTLET, OR CATCH BASIN. BOTTOM AND END OUTLET FITTINGS IN PVC ARE SIZED TO ACCEPT 3 IN OR 4 IN PIPE. BOTTOM AND END OUTLET FITTINGS ARE AVAILABLE IN PP WHERE CHEMICAL RESISTANCE IS NEEDED. END FITTINGS ARE UNIVERSAL FIT AND FIELD TRIMMED TO APPROPRIATE HEIGHT. GRATING OPTIONS INCLUDE DUCTILE IRON, GALVANIZED, STAINLESS STEEL, AND PLASTIC WITH LOCK DOWN FEATURE TO SECURE GRATE TO CHANNEL. GRATE LOAD RATINGS ARE AVAILABLE IN CLASSES A-E AND MAY BE SPECIFIED ADA COMPLIANT. REFER TO TRENCH CHANNEL TABLE FOR UPSTREAM (U) AND DOWNSTREAM (D) DEPTHS FROM TOP OF CHANNEL.

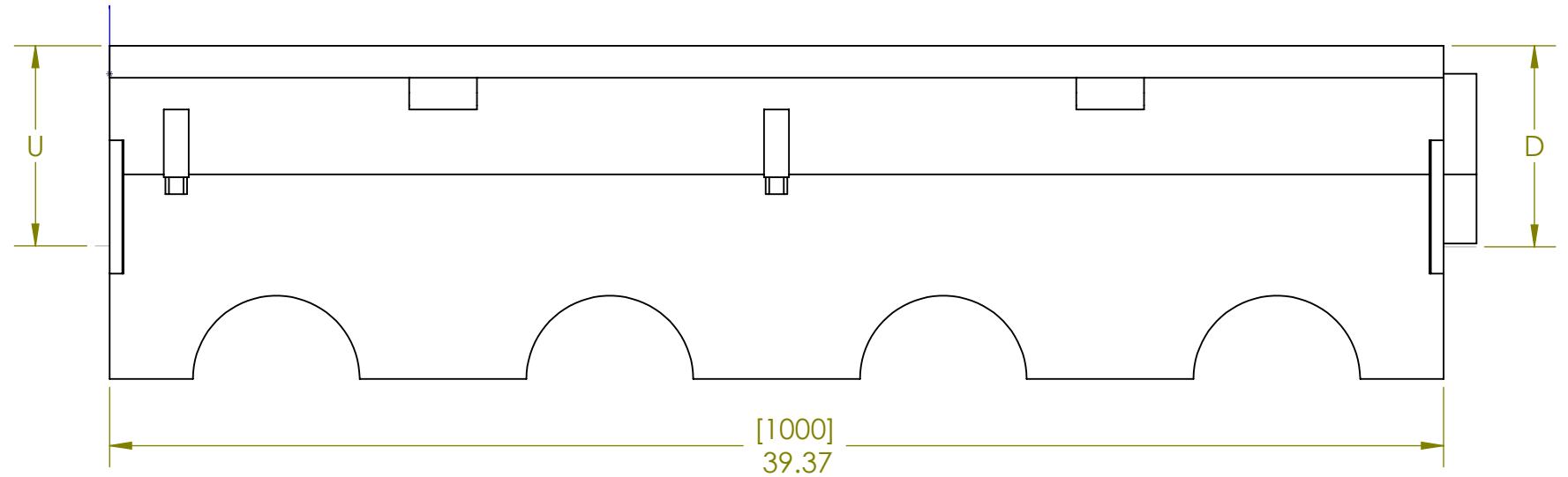
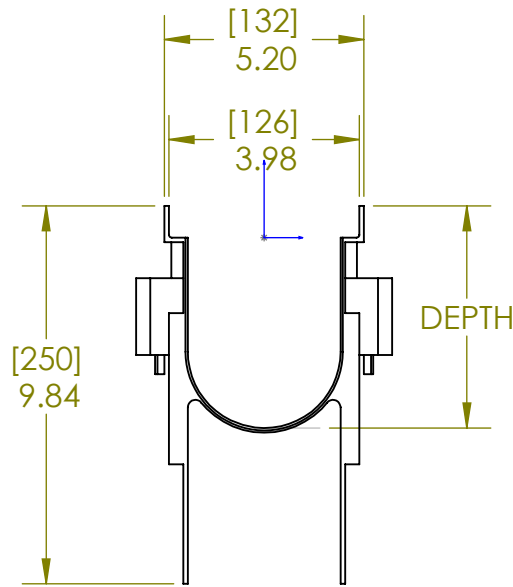
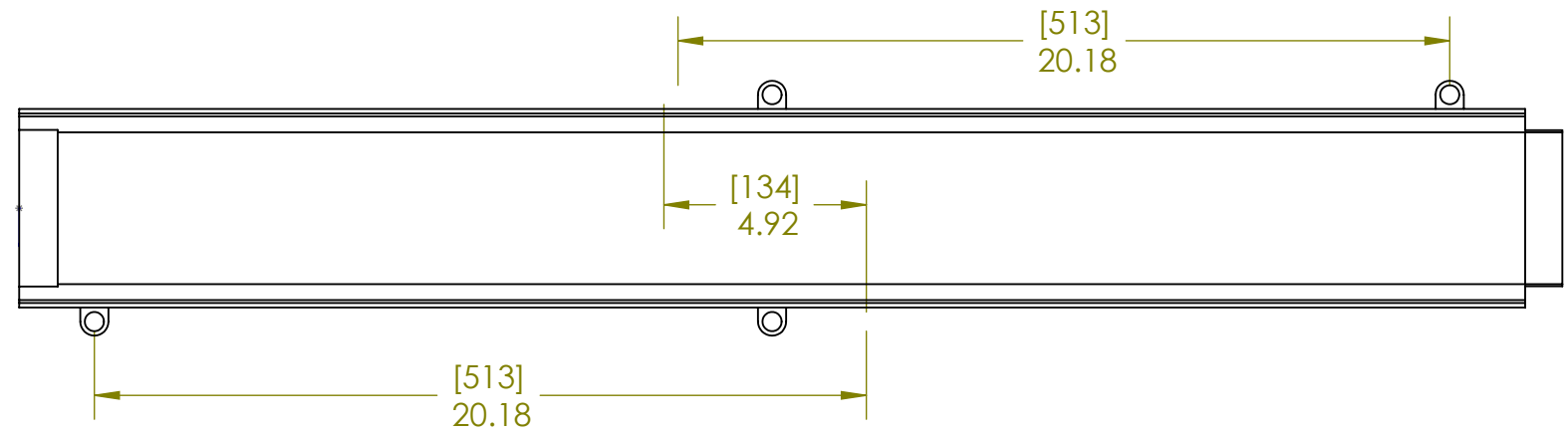

PROPRIETARY AND CONFIDENTIAL
THE INFORMATION CONTAINED IN THIS DRAWING IS THE SOLE PROPERTY OF LIGHTHOUSE INDUSTRIES. ANY REPRODUCTION IN PART OR AS A WHOLE WITHOUT THE WRITTEN PERMISSION OF LIGHTHOUSE INDUSTRIES IS PROHIBITED.

		UNLESS OTHERWISE SPECIFIED:		NAME	DATE	Quick Trench Series 6 Lighthouse Industries 107 Eastwood Road Michigan City, IN 46360 P: 219-879-1550 F: 219-879-1509	
		DIMENSIONS ARE IN INCHES		DRAWN	CB		11-3-2007
				CHECKED			
				ENG APPR.			
				MFG APPR.			
		INTERPRET GEOMETRIC TOLERANCING PER:		Q.A.			
		MATERIAL		COMMENTS:			
		PP 20% TF					
		FINISH					
		EDM					
NEXT ASSY	USED ON	APPLICATION		DO NOT SCALE DRAWING			
				SIZE	DWG. NO.	REV	
				B	Q6 -1000	0	
				SCALE: 1:5	SHEET 1 OF 1		