

8 7 6 5 4 3 2 1

D  
C  
B  
A

D  
C  
B  
A

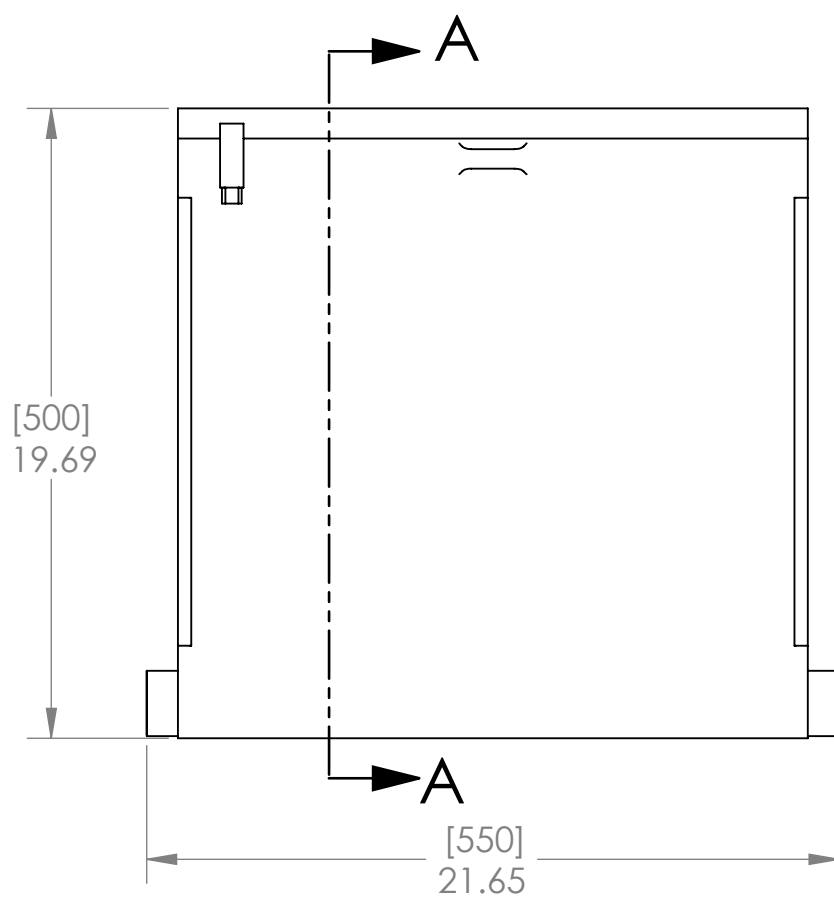
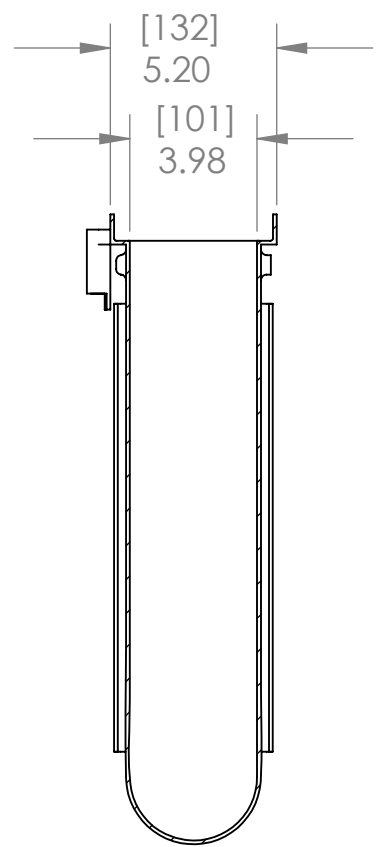
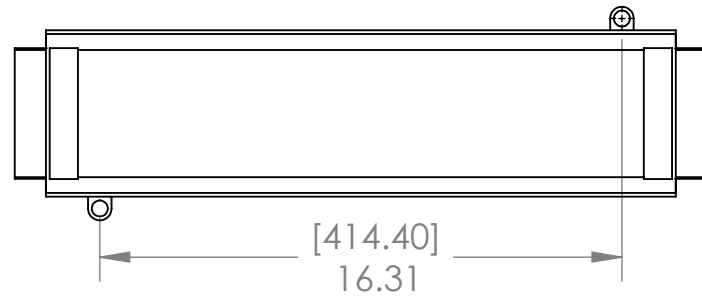

SECTION A-A  
SCALE 1 : 6

**PROPRIETARY AND CONFIDENTIAL**  
THE INFORMATION CONTAINED IN THIS DRAWING IS THE SOLE PROPERTY OF LIGHTHOUSE INDUSTRIES. ANY REPRODUCTION IN PART OR AS A WHOLE WITHOUT THE WRITTEN PERMISSION OF LIGHTHOUSE INDUSTRIES IS PROHIBITED.

		UNLESS OTHERWISE SPECIFIED:		NAME	DATE	Quick Trench Series 6 Lighthouse Industries 107 Eastwood Road Michigan City, IN 46360 P: 219-879-1550 F: 219-879-1509
		DIMENSIONS ARE IN INCHES	DRAWN	CB	11-4-2007	
			CHECKED			
			ENG APPR.			
			MFG APPR.			
		INTERPRET GEOMETRIC TOLERANCING PER:	Q.A.			<h2 style="text-align: center;">Catch Basin</h2>
		MATERIAL PP 20% TF	COMMENTS: Catch Basin			
		FINISH SPI NO. 4 / C-3				
NEXT ASSY	USED ON	APPLICATION	DO NOT SCALE DRAWING			SIZE <b>B</b> DWG. NO. Q6- CB-PP REV 0
						SCALE: 1:8 SHEET 1 OF 1

8 7 6 5 4 3 2 1